

T-SERIES

— delivering what matters —



SINGLE- AND MULTI-TEMPERATURE
SELF-POWERED REFRIGERATION SOLUTIONS FOR TRUCKS

CONTENT

T-Series: Delivering what matters	3
Introducing the T-Series	4
The GreenTech™ engine from Thermo King: Lowest emissions, highest performance	6
The new TSR and TSR-3 controllers: Most advanced, but easiest to use	7
Quality you can rely on	8
T-Series Spectrum™: Solutions for multi temperature distribution	10
T-Series Whisper™: Quieter operation, no compromises	11
T-Series heating option for extreme cold environments	12
Product segmentation	14
Features and options overview	15
Features and Options	16
Specifications	18
Multi temperature configurations	19

T-SERIES

Delivering what matters

Thermo King's new T-Series is the result of years of research and exhaustive testing. The T-Series sets new industry standards for reliability, performance, efficiency and low cost of ownership. The T-Series delivers greater capacities at lower operating speeds and allows for precise temperature control. Low operation and maintenance costs, as well as fuel saving technologies, keep cost of ownership to a minimum.

When Thermo King established performance criteria for the T-Series, high ambient capability was a "must have". Extensive field trials and thousands of running hours have proven the design able to perform in even the harshest of conditions, right up to 55°C. A heating option has been especially developed to ensure top performance at low ambients too.

Operation is easy and error-free, thanks to new, intuitive in-cab controllers. Ease of monitoring means the units will deliver optimum performance with maximum efficiency. The T-Series minimises an operator's carbon footprint with reduced exhaust emissions and less waste. Whisper quiet operation will allow access to noise sensitive urban delivery areas.

With the widest range in the truck refrigeration industry, there is a model to suit all trucks from the smallest to the largest, running one, two or three temperature zones.



Delivering what matters
Greater capacities
Maximum efficiency
Optimum performance

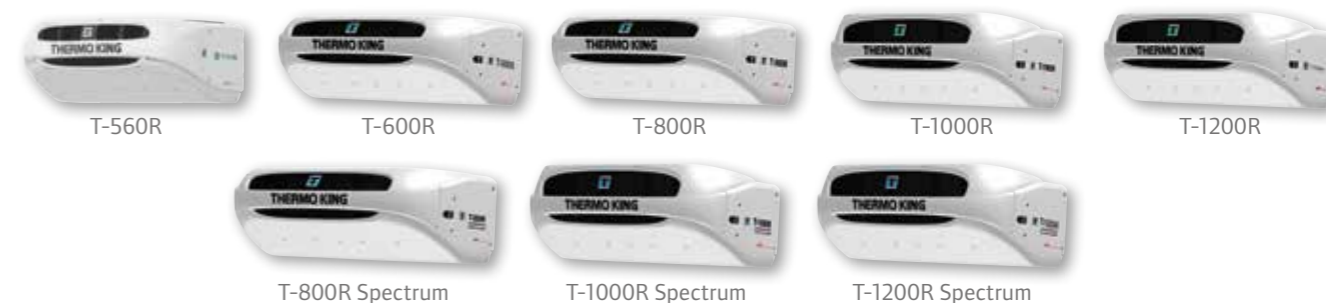

Introducing the T-Series

Lowest fuel consumption

- Through extensive development and field experience, Thermo King has found the right balance between system efficiency, fuel consumption and performance in all ambient conditions for both fresh and frozen produce
- Advanced technology such as the Truck Smart Reefer (TSR-3) controller and micro-channel condenser coils means greater fuel efficiency
- On the T-1200R and T-1200R Spectrum, an Electronic Throttling Valve (ETV) reduces engine emissions and increases fuel economy
- Faster pull-down means lower fuel consumption during pre-trip runs and in between door openings.

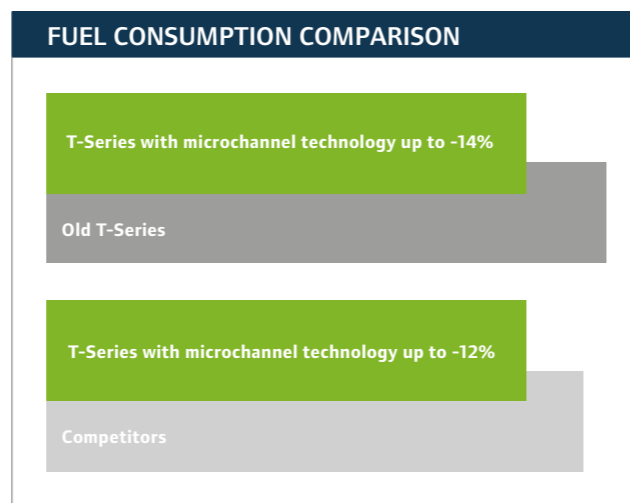

Lower life cycle costs

- The TSR and TSR-3 controllers allow optimum system management to give maximum protection at minimum operating cost for every type of load
- Extended Maintenance Interval (EMI) increases time between service intervals up to 2000 hours. This reduces maintenance, clean-up and disposal costs while extending engine life with highly efficient oil filtration
- All T-Series units come with a full two year warranty

Easy to use

- The intuitive TSR-3 controller features a symbolic display for error-proof operation
- Critical information is clearly displayed
- Service interval and scheduled maintenance reminders can be pre-programmed

Easy to service

- New external panel design allows improved service access to electrical and engine components
- ServiceWatch™ records system operation to reduce diagnostic time.

Reduced environmental impact

- All the T-Series range features GreenTech™ engines which are the cleanest on the market, exceeding all existing EU requirements for emissions control
- Micro channel condenser and radiator coil means up to 33% less refrigerant charge compared to old models and reduced environmental impact
- Extended Maintenance Intervals reduce oil, filter and coolant waste
- High gloss impact-resistant external panels mean 99.7% of the unit (by weight) is recyclable
- The T-Series range is manufactured at Thermo King's state-of-the-art facility in Galway, Ireland, which has held ISO 14001 certification for Environmental Management since 2000, and ISO 50001 certification for Energy Management Systems since 2012.

Up to 60% quieter operation

- T-Series Whisper™ technology dramatically reduces operating noise to permit access to noise sensitive areas
- Components including poly-V stretch belts with Quiet Channel technology and quiet fans reduce noise generation
- Super-absorbent foam reduces noise transmission

The toughest range in the industry

- An extensive range of single and multi temperature units means there is a model to suit all trucks, from the smallest to the largest
- There is a spread of cooling capacities to meet the most demanding applications:
 - 6200 to 12500 Watts at 0°C
 - 3400 to 6800 Watts at -20°C
- All models have been proven to perform right up to 55°C, the highest benchmark in the industry





The GreenTech™ engine from Thermo King

Lowest emissions, highest performance

All the T-Series truck refrigeration units are fitted with GreenTech engines from Thermo King. These engines drastically reduce emissions, waste and noise pollution, exceeding the most stringent EU standards (NRMM: Stage V compliant).

GreenTech™ engines are the cleanest engines on the refrigeration unit market. Performance has been enhanced too; more power means less component stress and longer life.

Engine life

The new engines run at no more than 80% of their maximum output. Thus, both oil and coolant temperatures are reduced, resulting in less component stress and less wear and tear on the engine.

Bio-fuel compatibility

All the new engines are approved for use with B7 fuel (7% bio/93% petroleum diesel) with no change in maintenance schedules. Fuels with higher bio-diesel content (B8 up to B100) require shorter intervals between oil changes and injector servicing. Thermo King Dealers can provide more information.

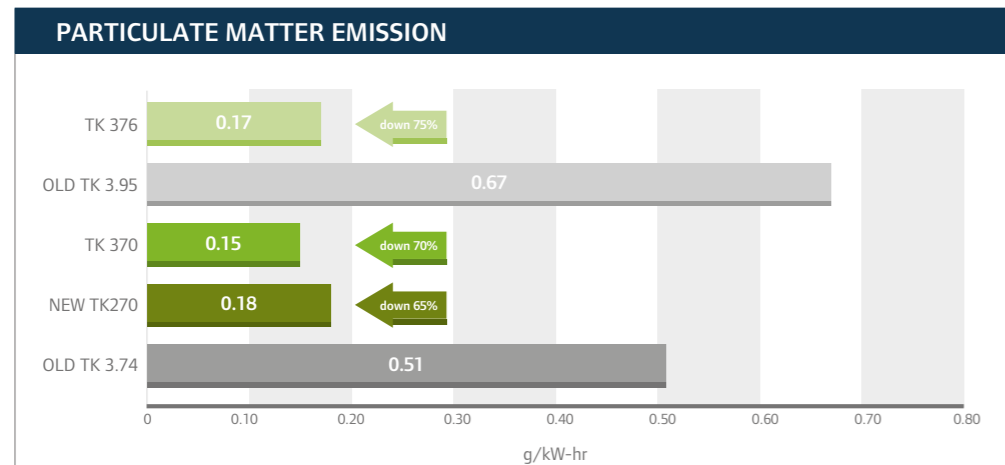

NRMM Stage V Compliance

Lowest emissions

Highest performance



With the new Thermo King GreenTech engines, emissions of particulate matter (PM) have been substantially reduced.

The new TSR and TSR-3 controllers

Most advanced, but easiest to use

Powerful and simple to use, the new TSR and TSR-3 T-Series controllers make it easy for drivers to accurately manage the temperature in the truck, no matter what the load being hauled. Step-by-step instructions, depicted in symbolic form, make it quick and easy to precisely set and adjust the refrigeration unit, helping your customers, your drivers and your business.



TSR and TSR-3 Standard in-cab display



TSR-3 Premium in-cab display

New intuitive interface

Drivers will find the new TSR (available on T-560R only) and TSR-3 Standard in-cab display easy to use and fully intuitive. Critical information is clearly displayed using LEDs which are unaffected by high cab temperatures. Numbers and symbols avoid the use of language and keep things simple. Buttons with illuminated symbols avoid the use of menus to select key functions including Cycle Sentry, high speed inhibit, defrost and pre-trip check. Set point changes are error-proof with colour coded up/down keys, set point temperature display and an enter key to confirm.

For even greater control of every aspect of a T-Series unit, a graphic TSR-3 Premium in-cab display is available as an option. The simple and logical menus, easy to read screen and choice of 21 languages make this the interface of choice for the advanced operator.

Fuel savings

The TSR and TSR-3 controllers include advanced features that deliver even greater fuel savings including:

- Cycle-Sentry™ mode
- ETV (T-1200R and T-1200R Spectrum only)
- Electronic door switch input

Improved diagnostics

The TSR controller includes the new Remote Watch service feature: a user-friendly web-based interface enabling on-the-road service and diagnosis, minimising truck downtime and reducing labour costs.

The ServiceWatch™ service logger is integrated in the TSR-3 controller and provided as standard.

- Enables faster and more accurate fault diagnosis
- Reduces downtime and labour hours
- Keeps a record of system operating modes and performance characteristics

Easy-to-read display

The new LED display is bright and clear, ensuring better visibility in all light conditions and at all ambient temperatures.

Enhanced safety and security

At the end of the day, protecting the load is what matters. The TSR and TSR-3 controllers make that job easier and even more effective with a range of enhanced features:

- Keypad with lock-out to avoid tampering
- Phase correction to avoid reverse fan rotation on electric standby
- Diesel/electric auto switching to protect cargo in the event of electrical power outage
- Set point warning to protect the load
- Oil and coolant level alerts to protect the engine
- Tiered security access levels for appropriate personnel to simplify operation and avoid operator error
- Diesel engine and electric stand-by hour meter display
- Data Acquisition System (DAS) and TracKing compatibility (Not available on T-560R)
- Password protection

Quality you can rely on

Thermo King's T-Series is the result of years of extensive research and stringent testing, ensuring each unit can provide unmatched reliability and operating economy. Rigorous procedures include non-stop endurance tests, accelerated life tests and exposure to extreme operating environments. All of these measures ensure that the T-Series leads the market for reliability, durability, economy and performance, even in the harshest conditions.

GreenTech Engine

- Low emissions
- High performance
- Increased life
- Reduced maintenance
- NRMM Stage V compliance

E-coated frame

- Automotive grade immersion electrocoating uses an electrical current to attract paint to metal
- Ensures complete paint coverage for total corrosion resistance
- Enhances unit life and protects resale value

Unit grille and panels

- Aerodynamic exterior panels help reduce vehicle fuel consumption
- Removable side doors give excellent service access
- Recyclable engineered plastic (Fibre-Reinforced Plastic for T-560R) is impact-resistant and has in-mould colouring to reduce and hide scratches, protecting the original good looks and resale value

Extended Maintenance Interval

- Up to 2000 hour / 24 month oil change intervals (whichever comes sooner)
- Reduced clean-up and disposal costs
- Reduced environmental impact with less spillage and less oil, filter and coolant waste
- Extended engine life with improved, highly efficient oil filtration
- Lower maintenance costs than competitor models

Powertray

- Poly-V stretch belt system delivers exceptional belt life
- High quality materials provide Quiet Channel technology

Electronic Throttling Valve

- On the T-1200R and T-1200R Spectrum, the ETV reduces engine emissions, increases fuel economy, improves temperature management and delivers faster pull-down.
- As the temperature approaches set point, the ETV begins to close, throttling the refrigerant gas returning to the compressor and thus reducing its cooling/ heating capacity. This provides very smooth and steady temperature control, resulting in ideal conditions for sensitive fresh produce. Less thermal shock means less weight loss through evaporation and therefore longer product shelf life.

Thermo King Reciprocating Compressors

- The industry standard for proven reliability and easy service
- Two and four cylinder compressors with extended life crankshaft bearings
- High efficiency due to more pumping capacity per cubic centimetre
- Proven reliability over millions of operating hours
- Field-repairable for easy service; no special tools or facilities required
- Greater than 10.000 hours service interval



X214 Compressor



X426 C5/X430 C5 Compressor

Coils

- Bigger condenser and evaporator coils give extreme ambient capability, more cooling capacity and more efficiency with less noise
- The latest in all-aluminium microchannel condenser coil design. Eliminates galvanic corrosion caused when copper and aluminium found in conventional coils react together
- Reduced fuel consumption and a smaller refrigerant charge mean reduced environmental impact
- Lighter and easier to clean

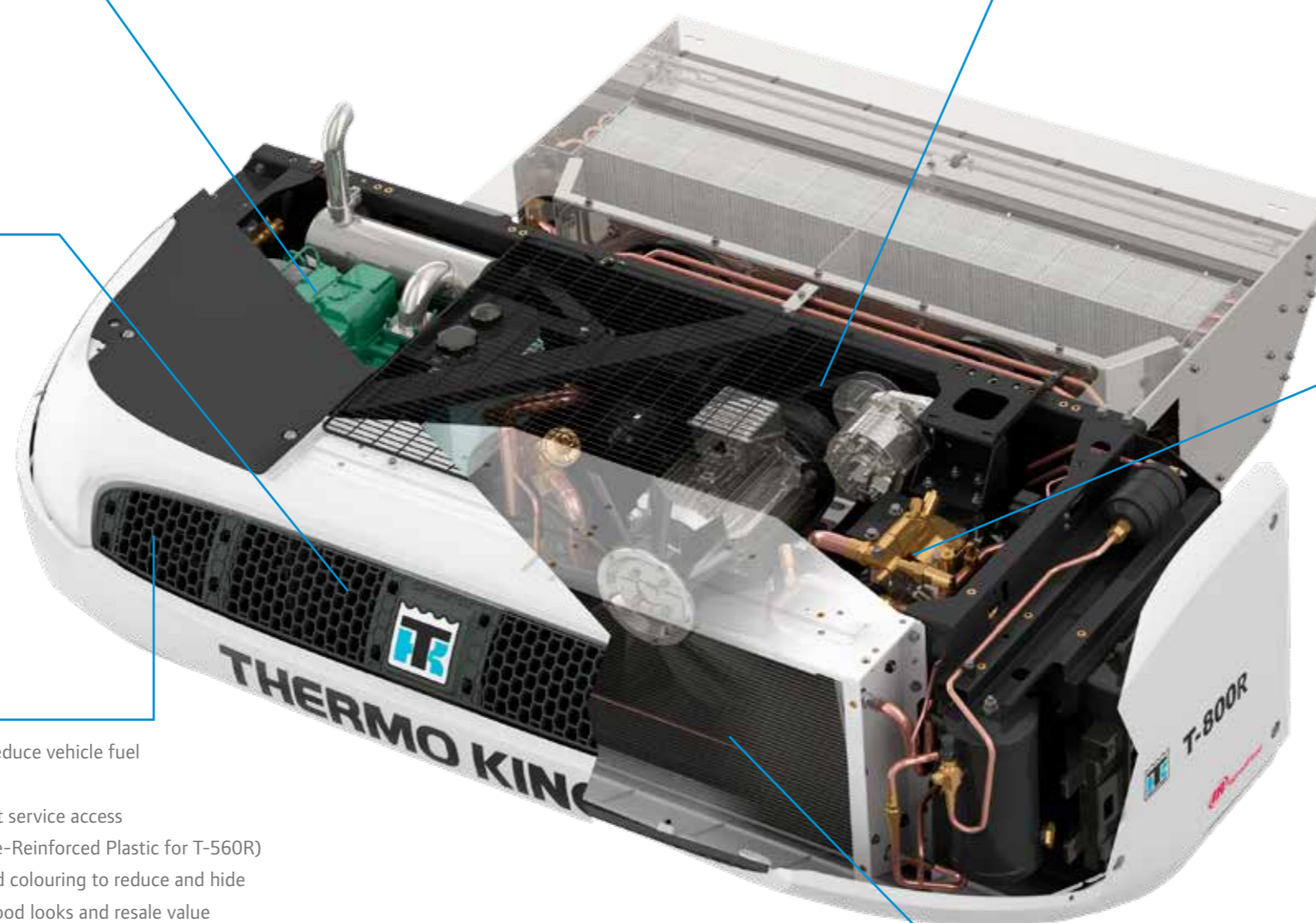

T-Series Spectrum™: Solutions for multi temperature distribution

The new range of T-Series Spectrum units will meet the extreme demands of any multi temperature distribution operation, thanks to the tireless focus on reducing noise levels and emissions, while maximising performance, efficiency and reliability.

Distribution operations are not all the same. That is why all T-Series Spectrum units are available with a choice of two or three blower remote evaporators that can be used in a number of different configurations. With the ability to support up to three zones in both compartment and lane applications, there is a solution to match every application. Thermo King Dealers can assist in selecting the right unit and configuration for your application.

Maximum performance for the most demanding operations

The T-1200R Spectrum has a class-leading 11800W of refrigeration capacity at 0°C box temperature, which even exceeds the performance of some trailer units. It does so by using advanced technology including an Electronic Throttling Valve. This ensures that product temperature is always maintained, even in the most severe ambient temperatures and with frequent door openings.

Using the TSR-3 controller and the latest in control software, the T-Series Spectrum operator can select from a range of programmable features to precisely tailor unit performance to the needs of the load carried, balancing temperature management and fuel economy.

Optional door switches are available to minimise temperature fluctuations during multiple delivery drops by automatically switching off the unit each time the doors are opened.



T-Series Whisper™: Quieter operation, no compromises

Noise is a critical consideration for all transport businesses but especially for distribution in urban areas.

Exhaustive sound analysis was conducted in Thermo King's acoustic laboratories to both contain noise and actually reduce it at source. Many components have been redesigned to perform at their optimum while minimising the generation of noise.

No compromises have been made on refrigeration capacity, even at extreme ambient temperatures where other equipment would simply shut down. This has been achieved by the use of larger condensers with Microchannel technology, low-noise fans, lower operating speeds and noise absorbing materials.

Class-leading low-noise performance

The T-Series Whisper™ was conceived and designed with ultra low noise as a key requirement, being up to 76% quieter compared to the standard T-Series models. The T-1000R and T-1200R Whisper™ models have been further optimised to ensure up to 75% less noise compared to their predecessors.

Even when compared to quiet technologies used by its competitors, T-Series Whisper™ is up to 20% quieter. That makes our units the optimum solution for your business, combining whisper-quiet operation with top-notch reliability, low fuel consumption and outstanding performance.

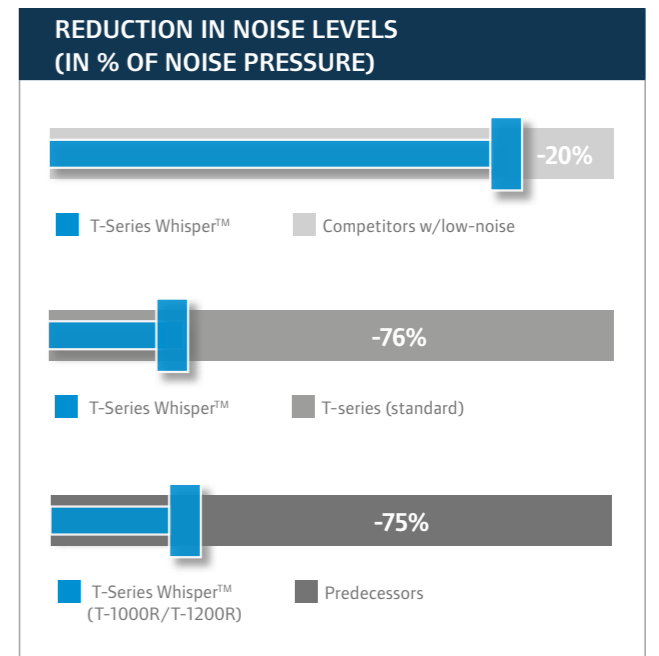

T-Series heating option for extreme cold environments

When delivering temperature sensitive cargo under extreme low ambient conditions, operators demand a reliable, durable refrigeration unit which will give maximum uptime while fully protecting their valuable cargo. In other words, complete peace of mind.

Customers in extreme low ambient conditions need refrigeration units with sufficient heating capacity to maintain loads in their optimum condition. To meet these special requirements, Thermo King has developed a means of capturing heat from the unit's engine coolant and using it to boost heating performance. A secondary coil is built into the evaporator through which the coolant is routed to give heating capacities which are up to double the conventional values.

With the T-Series Heating Option:

- T-600R and T-800R heating capacity on engine power is more than doubled to 6220W using water heat kit
- T-1000R is increased by 46% to 6000W with heat upgrade
- No additional refrigerant charge is needed for any of the above so there is no environmental impact
- Electric heater bars option gives an additional 1900W for all units on electric stand-by

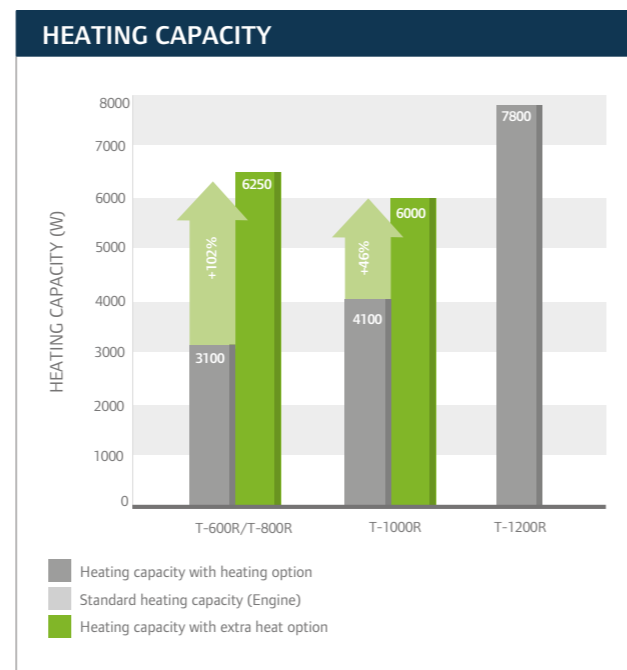

Specifications

PERFORMANCE	T-600R / T-800R	T-1000R	T-1200R
STANDARD HEATING CAPACITY: -18°C AMBIENT/2°C BOX TEMPERATURE			
Capacity on engine power (W)	3075	6000*	7800
HEATING CAPACITY WITH HEATING OPTION: -18°C AMBIENT/2°C BOX TEMPERATURE			
Capacity on engine power (W)	6220	N/A	N/A
Capacity on electric stand-by (W)	3600	4150**	6300**

* Contact your local dealer for further information
** With heater bars

Dimensions (mm)

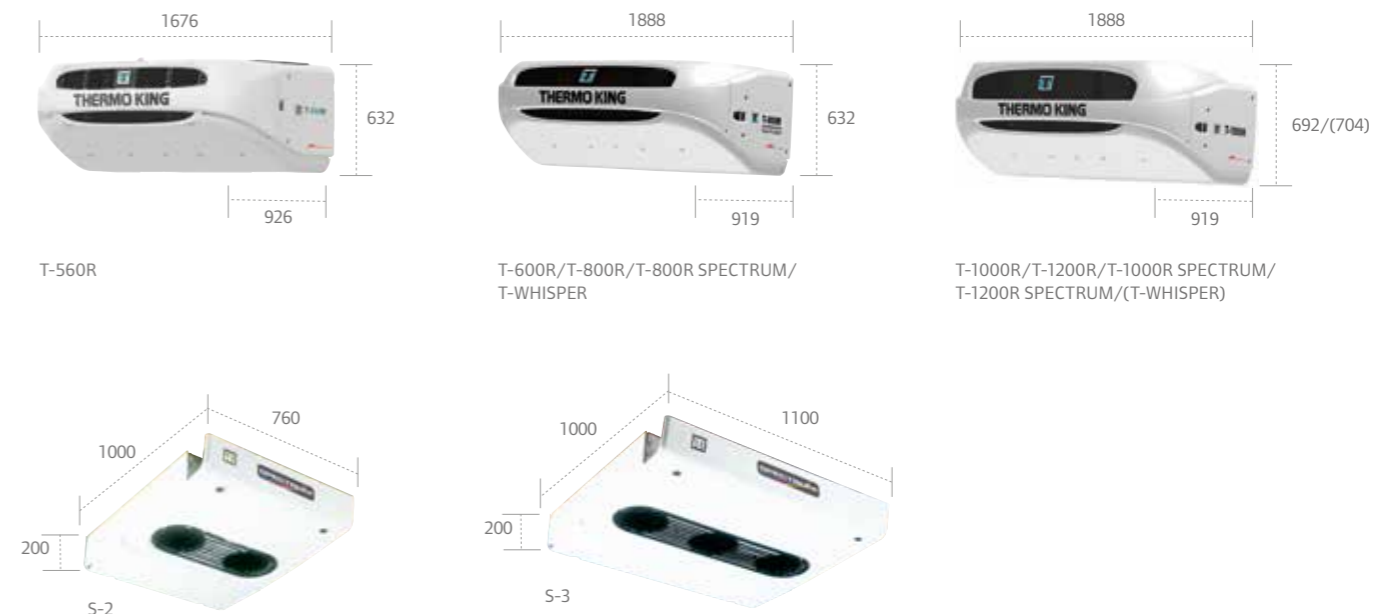

A model for every need
Top performance at all ambients

Product segmentation

SINGLE TEMPERATURE					
	4.0 to 6.0	5.5 to 6.5	6.5 to 7.5	7.5 to 8.5	> 8.5
Box length in metres					> 8.5 box length diagram"/>
T-Series					
	T-560R	T-600R	T-800R	T-1000R	T-1200R

*Depending on specific application

MULTI TEMPERATURE			
	6.5 to 7.5	7.5 to 8.5	> 8.5
Box length in metres			> 8.5 box length diagram"/>
T-Series Spectrum			
	T-800R Spectrum	T-1000R Spectrum	T-1200R Spectrum

*The above recommendations are for average running conditions and will be affected by operational factors such as ambient temperature and door openings.

To ensure the best selection for your application please contact your Thermo King representative.

Features and options overview

FEATURES AND OPTIONS	T-560R	Single temperature T-600R/T-800R/ T-1000R/T-1200R	Multi temperature T-800R/T-1000R/ T-1200R Spectrum
LIFE COST MANAGEMENT			
ThermoKare Service contracts	▲	▲	▲
Two year warranty coverage	●	●	●
Cycle-Sentry start/stop control system	●	●	●
EMI (Extended Maintenance Interval) 1000 hour*	●	○	○
EMI (Extended Maintenance Interval) 2000 hour*	○	●	●
TK Battery - EnergyOne Silver (Wet Cells 640 CCA)	●	●	●
TK Battery - EnergyOne Gold (Wet Cells 760 CCA)	△	△	△
TK Battery - EnergyOne Platinum (AGM 880 CCA)	△	△	△
DATA CAPTURE & COMMUNICATIONS			
DAS (Data Acquisition System)	○	△	△
TouchPrint data capture	▲	▲	▲
TrackKing (tracking and load monitoring)	○	▲	▲
Wintrac (data analysis software)	○	▲	▲
TouchPrint Printer	▲	▲	▲
Remote Watch	●	○	○
LOAD PROTECTION			
Auto phase correction	●	●	●
Diesel/electric auto-switching	●	●	●
Door switches	△ ▲	△ ▲	△ ▲
Standard in-cab display	●	●	●
Heater Bars Kit	▲	△ ▲	△ ▲
Water Heater - (T-600R/T-800R only)	○	△	○
CUSTOMIZATION			
Premium in-cab display	○	△	△
Whisper kit acoustic	△	△	△
Evaporator guard	○	○	▲
Rear remote control	△	△	△
Body mount enclosure	▲	▲	▲
Fuel tank plastic 90L	△ ▲	△ ▲	△ ▲
Drain kit	○	○	▲
Fuel level sensor	○	△ ▲	△ ▲
ServiceWatch maintenance logger	○	△	△
Triple combo display	▲	▲	▲
Flexible hoses	○	○	○
Electronic fuel capture	○	▲	▲
Remote status light and combination display	○	○	○
Hose management kit	△	△	△
ThermoLite™ Solar Panel	▲	▲	▲

○ Not available ● Standard feature △ Option: factory supplied ▲ Option: dealer supplied



WARRANTY CONDITIONS

Thermo King warrants the new product delivered will be free of defects in material and workmanship for the period of time specified in the applicable warranties. Specific terms of the Thermo King warranty are available on request.

Features and Options

Warranty coverage

2 year warranty coverage on unit and options



ThermoKare™

ThermoKare offers a complete selection of service contract solutions to manage maintenance costs and hence total life cost of a unit.

Cycle-Sentry

This stops the engine when refrigeration is not needed and restarts it when refrigeration or battery charge is needed.

- Fuel and CO₂ savings of up to 80%
- Increased component life
- Reduced maintenance costs

Extended maintenance interval

Thermo King EMI 2000 (EMI 1000 for T-560R) will extend your maintenance interval and reduce your operating costs by:

- Reducing clean-up and disposal costs
- Reducing environmental impact with less spillage and less oil, filter and coolant waste
- Extending engine life with improved, highly efficient filtration

Thermo King EnergyOne Silver Battery

- Incorporates silver-calcium technology to extend service life over 20% longer than conventional batteries

Thermo King EnergyOne Gold Battery

For customers that operate in colder climate conditions, this 760 CCA upgraded wet cell battery delivers greater power than the standard battery.

Thermo King EnergyOne Platinum Battery

- Uses Absorbed Glass Mat (AGM) technology with deep-cycle capability and exceptional cranking power (880 CCA)
- Maintains capacity at low temperatures better than a wet cell battery
- Five to eight year service life, backed by a 2 year warrant, saves the cost of frequent battery replacements.

Data Acquisition System (DAS)

This high performance data logging system records temperatures, set point, operating modes and external events.

- Data can be output to a computer or printer
- Operates independently of unit controller
- Memory storage for over one year's data
- Assures customer of total quality control
- Provides evidence of correct practice
- Approved to EN-12830, CE mark and IP-65 standards
- Up to 6 independent sensors
- Automatic power-up and shut-off to protect unit battery

Thermo King Engine Block Heater

For customers that operate in colder climate conditions, the Thermo King Engine Block Heater pre-heats the engine and allows it to start more easily, thereby suffering less wear, consuming less fuel and increasing battery life.

TouchPrint data capture

- Thermo King's TouchPrint data logger is compact, easy to use, flexible to download and quick to generate printouts
- Intuitive and clear touchscreen display
- Temperature sensors and Thermo King set point reading
- Soft copy export of tickets to USB flash drive
- High speed thermal printer for quick printout
- Large flash memory to hold min. 1 year of data

TrackKing

Get complete load monitoring and fleet tracking at your fingertips.

- Monitors sensitive loads via the web
- Increases truck asset utilisation
- Reduces operating costs
- Enhances customer satisfaction
- Increases security and reduces insurance risk
- TrackKing can be sold with a ThermoKare service contract
- TrackKing is compatible with all Thermo King dataloggers and the TSR-3 controller
- More information at www.tktracking.com

Wintrac (data analysis software)

User-friendly software offers fleet managers automatic and customised reporting of temperature and operational data logged by DAS, TouchPrint or transmitted by TrackKing.

Remote Watch

New feature (available on the T-560R only) which allows the Thermo King service team to remotely access the unit from anywhere in the world. Only requires a device with a USB port and an internet connection. User-friendly web interface providing on-the-road service, therefore minimising downtime.

Auto phase correction

- Avoids reverse fan rotation while on electric stand-by
- Protects your load

Diesel/electric auto switching

- Automatically starts diesel engine if electric stand-by fails
- Manual override for ferry operation
- Protects the load automatically (without manual intervention)



Door switches

- Reduce load temperature rise and save fuel when doors are opened

TSR and TSR-3 standard in-cab display

- Simplified keypad to reduce the risk of incorrect operation of the system
- Visible set point confirmation for load protection
- Programmable features to tailor operating conditions to the load

TSR-3 premium in-cab display

- Even greater control of every aspect of a T-Series unit
- Access to all programmable features on TSR-3
- Simple and logical menus, easy to read screen and choice of 21 languages

Whisper™ noise attenuating kit

The Whisper™ low noise kit reduces noise levels of the applied unit significantly over standard T-Series units.

Evaporator guard

- Maximum protection against evaporator damage during loading and unloading
- Easy to install
- Exceptional quality

TSR-3 rear remote control

- Allows control of the refrigeration unit from inside the rear of the truck
- Enables energy efficient and safe loading

Body mount enclosure

- Allows external mounting of in-cab displays on truck body (for swap body and drawbar trailer applications)

Exclusive driver training software

Thermo King's Tutor Series with "Professor Kool" provides rapid and effective interactive training to reduce driver error and ensure optimum equipment operation.



Specifications

SPECIFICATIONS	T-560R	T-600R	T-800R	T-1000R	T-1200R	T-800R SPECTRUM	T-1000R SPECTRUM	T-1200R SPECTRUM
REFRIGERATION CAPACITY: SYSTEM NET COOLING CAPACITY AT 30°C AMBIENT TEMPERATURE UNDER ATP CONDITIONS								
Return air to evaporator	0°C	-20°C	0°C	-20°C	0°C	-20°C	0°C	-20°C
Capacity on engine power	W	6300	3500	6800	4000	8000	4200	9600
Capacity on electric stand-by	W	4800	2500	4800	3200	6000	3200	6700
AIRFLOW ON HIGH SPEED ENGINE OPERATION								
Airflow Volume @ 0Pa static pressure	m³/hr	2150	2700	2700	3200	3300	Refer next page	Refer next page
WEIGHT*								
Model 30: cooling and heating on engine operation	kg	370	441	444	457	460	357	373
Model 50: cooling and heating on engine and electric stand-by operation	kg	400	473	477	514	517	389	430
ENGINE: LOW EMISSIONS, LIQUID COOLED								
Model		TK 270	TK 370	TK 370	TK 376	TK 376	TK 370	TK 376
Rating	kW	7.5	11.2	11.2	14.6	14.6	11.2	14.6
Maintenance Interval	hrs	1000	2000	2000	2000	2000	2000	2000
COMPRESSOR: LIGHTWEIGHT ALUMINIUM ALLOY								
Model		X214	X214	X214	X426 C5	X430 C5	X214	X426 C5
Displacement	cc	228	228	228	424	492	228	424
ELECTRIC STAND-BY OPTION								
Voltage / Phase / Frequency		400V/3Ph/50Hz 230V/3Ph/50Hz 230V/3Ph/60Hz						
Rating	kW	4.5	4.5	4.5	7.5	7.5	4.5	7.5
REFRIGERANT: R-404A ZERO OZONE DEPLETION POTENTIAL (ODP), INTERNATIONALLY APPROVED, ATP CONDITIONS								
Charge	kg	2.6	3.4	3.6	3.4	3.8	4.0**	5.86**
REFRIGERANT: R-452A, FUTURE PROOF COMPLIANCE WITH F-GAS REGULATIONS (2020 REVISION)								
Charge	kg	2.6	3.4	3.6	3.4	3.8	6.0**	6.1**

*These weights don't include battery

** Actual charge required for Spectrum units is dependent of installation layout and configuration
Specifications are subject to change without notice.

REMOTE EVAPORATORS	S-2	S-3
REFRIGERATION CAPACITY: SYSTEM NET COOLING CAPACITY AT 30°C AMBIENT TEMPERATURE UNDER A.T.P. CONDITIONS		
Return air to evaporator	0°C	-20°C
Capacity	W (up to)	6300
AIRFLOW		
Airflow volume @ 0 Pa static pressure	m³/hr	1420
Discharge velocity (air throw)	m/sec	9.5
WEIGHT		
	kg	36

Airflow volume and weight will be cumulative. Capacity will depend on unit configuration.

S-4 configuration = S-2+S-2

Multi temperature configurations

Zone configurations

	HOST	REMOTE
A	T-1000R, T-1200R Spectrum	S-3 + S-3
B	T-800R, T-1200R, T-1000R Spectrum	S-2 + S-3
C	T-1000R, T-1200R Spectrum	S-4 + S-2
D	T-1000R, T-1200R Spectrum	S-3 + S-3
E	T-800R, T-1000R Spectrum	S-3 + S-2
F	T-800R Spectrum	S-2 + S-2
G	T-800R Spectrum	S-2 + S-2
H	T-1200R Spectrum	S-4 + S-4
I	T-1200R Spectrum	S-4 + S-2
J	T-1200R Spectrum	S-4 + S-3
K	T-1000R, T-1200R Spectrum	S-2 + S-2 + S-2
L	T-1000R, T-1200R Spectrum	S-2 + S-2 + S-2
M	T-1200R Spectrum	S-3 + S-3 + S-2
N	T-1200R Spectrum	S-3 + S-2 + S-2
O	T-1200R Spectrum	S-2 + S-2 + S-3
P	T-1200R Spectrum	S-4 + S-2 + S-2

Zone plans

2 zones

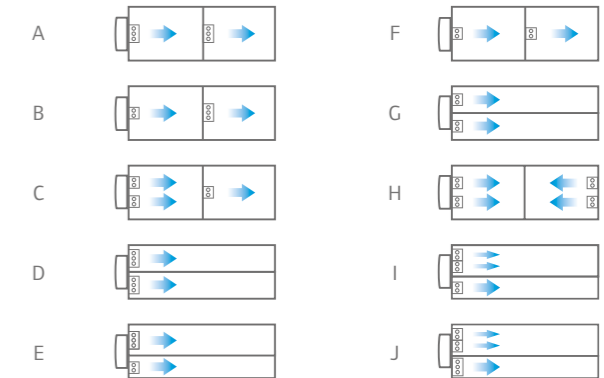

3 zones

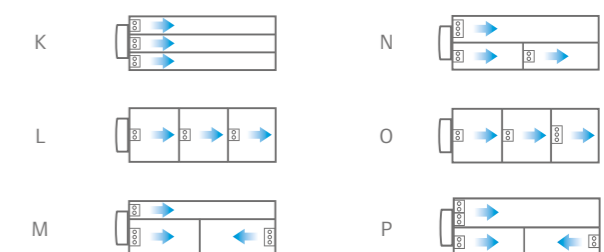



THERMO KING

Thermo King – by Trane Technologies (NYSE: TT), a global climate innovator – is a worldwide leader in sustainable transport temperature control solutions. Thermo King has been providing transport temperature control solutions for a variety of applications, including trailers, truck bodies, buses, air, shipboard containers and railway cars since 1938.

For further information, please contact:

europe.thermoking.com

Find your nearest dealer on

dealers.thermoking.com

TRANE
TECHNOLOGIES